

Building on BACnet® Connecting BAS Devices to an IP Infrastructure



Contemporary Controls is your ideal partner for applying network technology to your BACnet building automation project. The industry is embracing Ethernet connectivity to Direct Digital Controllers (DDC) along with open protocols such as BACnet. Access to the Internet is now assumed. With over 30 years of networking experience, primarily assisting building automation OEMs, Contemporary Controls has the expertise in guiding customers through the network maze. With locations around the world, and a reputation for technical support, Contemporary Controls can assist in making your building automation projects successful.

Building on BACnet

BACnet, an open-system protocol and international standard, provides the customer with vendor independence. BACnet-compliant equipment can be purchased from many vendors, and implemented at more than one level. The lowest level has digital/analog sensors and actuators individually connected to a controller or remote I/O device. The next level has BACnet MS/TP intelligent devices sharing an EIA-485 network. Above that BACnet/IP Ethernet takes full advantage of rich BACnet objects and services directly tied to an IP Ethernet network. The Internet on the highest level is accessed via IP routers. Contemporary Controls makes all this work using our BACnet and CTRLink Ethernet infrastructure products.

The BAS Remote family of remote I/O, gateway and controller products allows for a convenient expansion of BACnet systems in the field. Compliant with the BACnet B-ASC device profile, these units provide six universal I/O points and two relay outputs. Each I/O point can accept an analogue signal or generate an analogue signal of 0-10 VDC or 0-20 mA, in addition to providing input capability for thermistors, contact closures and pulses. The BAS Remote is powered from a 24 VAC/VDC source while providing a 24 VDC loop supply for transmitters.

There are several models. The BAS Remote Master is BACnet/IP compliant and has a 10/100 Mbps Ethernet port. Configuration is accomplished via the unit's web server. It can also function as a Modbus TCP server, a 2-wire Modbus serial gateway to BACnet, and a Sedona Framework™ controller.

Up to three BAS Remote Expansion Modules attached to a BAS Remote Master can greatly increase point count.

The BAS Remote Master PoE adds IEEE 802.3af compliance with power derived from its Ethernet port.

The BAS Router connects BACnet/IP Ethernet to BACnet MS/TP allowing MS/TP gear to connect to the building's IP network. The unit has a 10/100 Mbps Ethernet port and an opto-isolated MS/TP port with configuration via its web server. It mounts on DIN-rail and is powered from a 24 VAC/VDC source.

The BAS Portable Router provides the same functionality but in a small plastic case for use with a laptop PC, making it ideal for commissioning and troubleshooting. It is USB powered from the laptop but communicates via the laptop Ethernet port.



BAS Remote



BAS Router



BAS Portable Router

Building on BACnet®

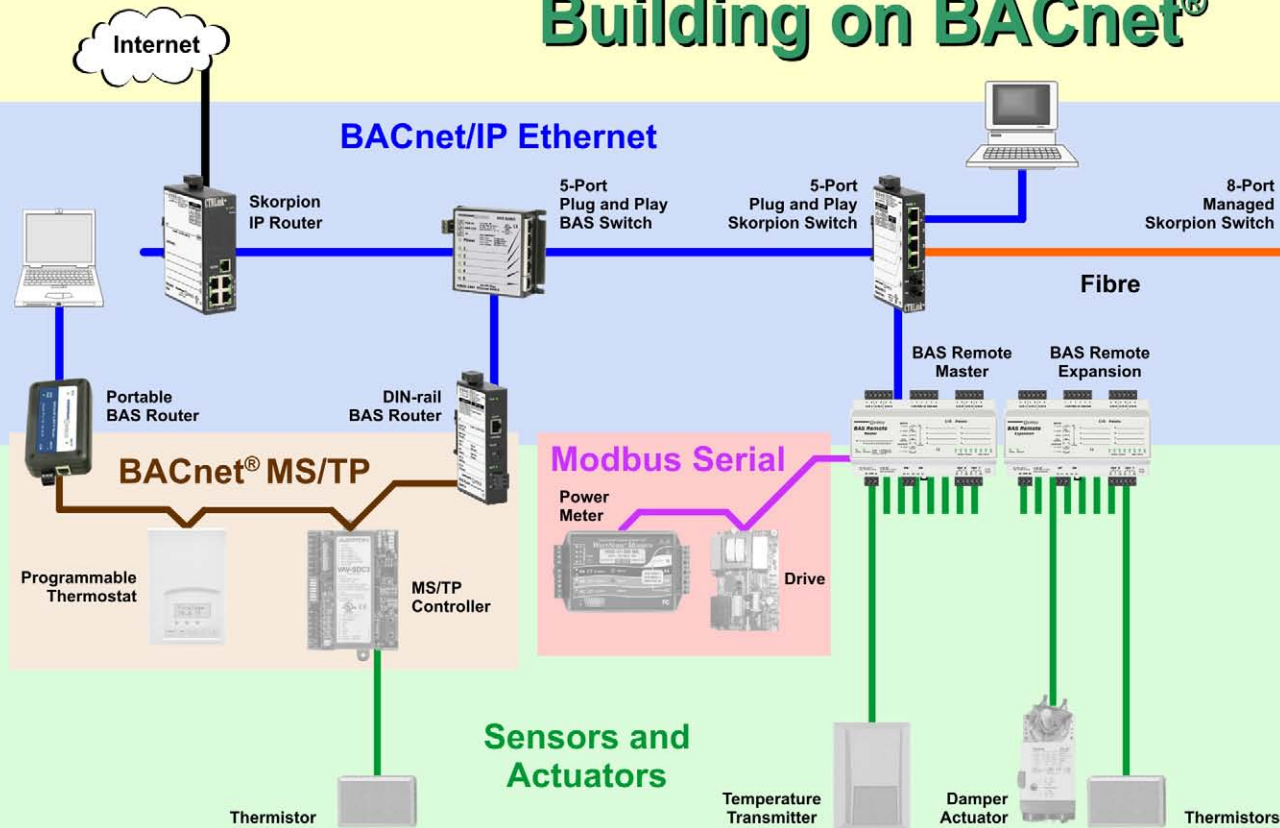

Use Your Existing Ethernet Infrastructure and Save

Why pull proprietary building automation cabling when you already have Ethernet cabling in place? Buildings are being designed with an Ethernet infrastructure to carry phone and data services. With BACnet/IP you can attach to this existing infrastructure, eliminating the need to install dedicated BAS cabling. With the BAS Remote Master, a direct connection to Ethernet is provided. Simply attach your analogue and digital I/O points to the BAS Remote's universal I/O connections and you are up on Ethernet without the need for an external router. This saves the cost of purchasing and installing the cabling and may gain you LEED's points as well.

Oops! I Missed a Point

Perhaps someone forgot to pull cable to a distant point or you need to add another point and no BAS cable is there. Why not use the existing Ethernet infrastructure? If you have some BACnet MS/TP devices to install, but no MS/TP home run is available, use a BAS Router to make the BACnet/IP to BACnet MS/TP connection. This would allow any BACnet/IP device attached to the Ethernet infrastructure the ability to communicate to your MS/TP devices regardless of their location. Do you need to inquire about a point on an MS/TP network from your laptop? Use the BAS Portable Router instead.

Link®

Ethernet Built for Buildings

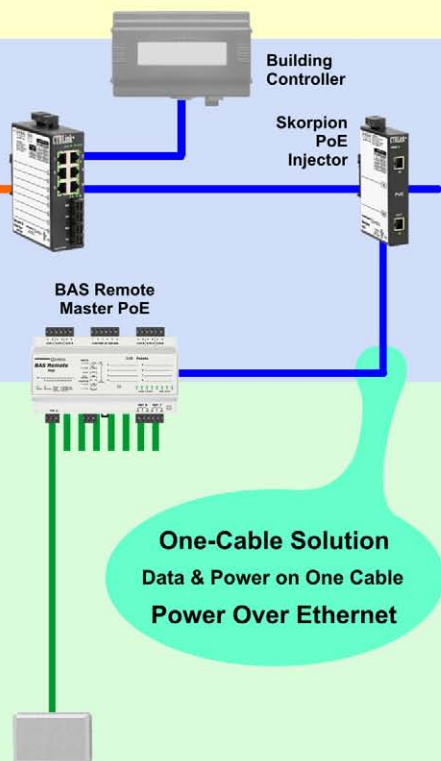

Trademarks

Contemporary Controls, ARC Control, ARC DETECT, EXTEND-A-BUS, RapidRing, and CTRLink are registered trademarks of Contemporary Control Systems, Inc. Specifications are subject to change without notice. Other product names may be trademarks or registered trademarks of their respective companies. BACnet is a registered trademark of the American Society of Heating, Refrigerating, and Air-Conditioning Engineers Inc. (ASHRAE). Powered by Sedona Framework is a trademark of Tridium, Inc.

The One Cable Solution — Power Over Ethernet (PoE)

The BAS Remote Master PoE is unique in its ability to communicate over Ethernet while deriving power for itself and attached I/O devices over the same cable. Connecting to equipment without a fieldbus drop or low-voltage power is now easy if an Ethernet port is available. By installing the BAS Remote near field devices, power can be obtained over Ethernet if IEEE 802.3af power-sourcing equipment (PSE), such as Contemporary Controls' PoE injector, is at the other end of the cable. Since the BAS Remote can power both attached input and output devices, it is only necessary to power the BAS Remote which then powers connected devices. The only limitation is the total power drawn over Ethernet — if total consumption caps at 13 watts, the One Cable Solution is viable.

Powered By Sedona Framework™ Controller

The BAS Remote supports open system protocols such as BACnet, Modbus and now Tridium's Sedona Framework. A Sedona Virtual Machine is included in the BAS Remote, enabling the BAS Remote to execute stand-alone control schemes while benefiting from the ease of drag-and-drop programming. The BAS Remote retains its web server configuration capability and its ability to communicate over a BACnet/IP network while functioning as a true application specific controller (ASC).

The Sedona Framework has a seamless interface to IP networks and can directly connect to Tridium's Niagara Framework — a popular building automation integration platform — via the BAS Remote's Ethernet port using the SOX protocol. Programming is accomplished using either a Niagara Workbench or Sedona Workbench over Ethernet. A rich collection of Sedona Framework function blocks, including PID loops, are interconnected on a wire sheet using virtual wires. Once the program is developed, it is stored on the BAS Remote and executes when powered up.

POWERED BY
SEDONA
FRAMEWORK™



Plug-and-Play Switches



Managed Switches



Automation Switches



Media Converters



PoE Injector



IP Router



Industry Specific Switches

CTRLink®

Ethernet Built for Buildings

Ethernet has rapidly become the network of choice for intelligent buildings due to its high speed, familiarity among users, and ability to easily connect to the Internet. But the environment can be demanding. The equipment must be robust, reliable, and easy to install, maintain and use. It must carry proper regulatory approvals and, in some instances, withstand outdoor temperatures. Office-grade equipment, with its frequent model changes and inconvenient mounting, will not do.

Equipment performance can range greatly. For simple systems, **plug-and-play** units will suffice. These products will operate “right out of the box” and can be put into service without adjustments. Auto-negotiation is standard where data rate (10/100 Mbps) and duplex (half or full) are set between link partners without user intervention. DIN-rail and panel-mounting are standard, as is 24 VAC/VDC power. More demanding applications require managed switches that support the SNMP protocol — providing data on network health and the ability to configure the network. Advanced functions like redundancy, IGMP snooping, VLANs and priority tagging can be found in Contemporary Controls’ **managed switches**.

For high port count or head-end installations, **automation switches** are often used. Along with all the same features found in the company’s managed switch software (M-Software), there is support for IEEE 802.3af Power Over Ethernet (PoE). Up to eight ports within a 24-port switch can source PoE power.

For long runs up to 15 km and inherent immunity to electromagnetic interference, use **media converters** or switches with fibre ports. Media converters make the copper-to-fibre transition quick and efficient. Both single-mode and multimode fibre are supported. For powering a single-port PoE device, a **PoE injector** can be used.

An **IP router** connects two Internet Protocol (IP) networks — passing necessary traffic while blocking all other traffic. Ethernet-to-Ethernet routing is supported via a four-port internal switch.

In some instances, agency approvals (beyond that normally required for an Ethernet switch) are needed — requiring an **industry specific switch**. Contemporary Controls has worked with OEMs in obtaining UL 864 compliance on our Ethernet switches, and can help in other areas such as private-labelling, unique packaging or extreme environmental design.

Our Social Responsibility

Within today's innovative global community, our most significant priority is to meet the needs of the manufacturing sector without forfeiting our commitment to the betterment of society. We approach our business with a strong focus on growth while providing a responsible, environmentally-conscious workplace with sound business procedures.

We hold every aspect of our business to the highest ethical standards, from our research and development to our sales and customer service. Our customers depend upon us to understand their unique needs and deliver the products and services that allow them to attain their goals. Because we treat our suppliers like partners, we maintain a strong supply chain to reliably meet our customers' schedules.

Contemporary Controls is committed to making our manufacturing process as environmentally sustainable as possible. We have converted all of our manufacturing facilities to lead-free operation. We provide in-depth personnel training and practice "lean" manufacturing initiatives. Our efforts ensure that our products, processes and services contribute to the renewal of the earth's ecology for the next generation. Because of our progressive manufacturing processes, all our products are RoHS compliant.

Our pursuit of sustainable manufacturing means we fully support environmental legislation. We adhere to the goals of reducing energy consumption, reducing the amount of hazardous materials in our environment, greater recycling, reducing the waste in landfills and the use of fewer natural resources. Our company follows the Waste Electrical and Electronic Equipment (WEEE) directive.

We realize the significance of our actions, and we are a responsible partner in facing the challenges of today and tomorrow.

Our Quality Policy

Our **CORE VALUES** and **BELIEFS** are the foundation on how we conduct business.

- Our customers depend upon us to deliver products and services that meet their needs. Their success provides us the means to exist.
- Our suppliers are important to our success and, therefore, we treat them as partners.
- Each employee is considered a professional, independent of position, and contributor to the success of the organization.
- We are all members of a working team, striving to develop innovative products, technologies, and processes.
- We stress quality in everything we do and know we can do better through continuous improvement efforts.
- The ethical way of doing business is the only way.

Our **PURPOSE** is to develop, manufacture, and market networking technology to the benefit of our automation customers worldwide.

Worldwide Locations



Contemporary Control Systems, Inc.
2431 Curtiss Street
Downers Grove, IL 60515
USA
info@ccontrols.com
www.ccontrols.com

Contemporary Controls Ltd
Sovereign Court Two
University of Warwick
Science Park
Sir William Lyons Road
Coventry, CV4 7EZ
United Kingdom
info@ccontrols.co.uk
www.ccontrols.eu



Contemporary Controls (Suzhou) Co. Ltd
11 Huoju Road
Science & Technology Park
New District, Suzhou
PR China 215009
info@ccontrols.com.cn
www.ccontrols.asia

Contemporary Controls GmbH
Fuggerstraße 1 B
04158 Leipzig, Germany
Tel: +49 341 520359 0
Fax: +49 341 520359 16
info@ccontrols.de
www.ccontrols.eu



CONTEMPORARY CONTROLS®